



Technical Data

Evolve Cubicles

Floor-Anchored, Overhead-Braced Compact Grade Laminate (CGL)

SPECIFICATION:

Height: Overall Cubicle Height: 82 5/16" (2091mm)
Standard Door Height: 71 5/16" (1811mm) with 9" (229mm) floor clearance
Panel Height: 72" (1829mm) with 9" (229mm) floor clearance

ELEVATION:

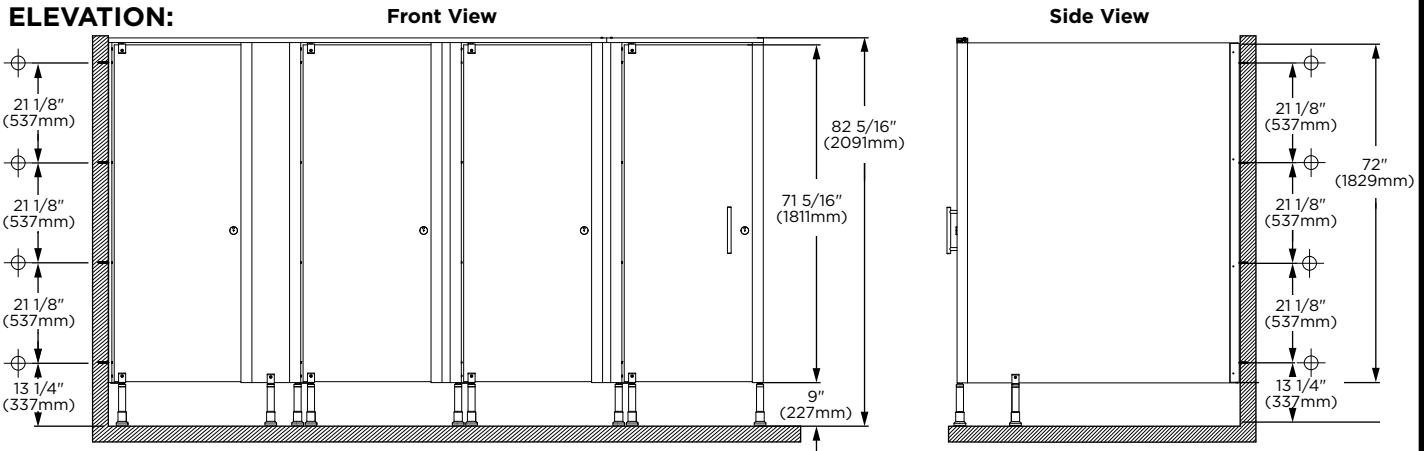

⊕ These mounting points require backing.

MATERIAL:

Framework— Fully anodized aluminum frame including extruded aluminum headrail and vertical posts. Closing latch locks into vertical frame post, including buffers.

Door— Class-A Fire-Rated Compact Grade Laminate (solid phenolic) 1/2" (12.7mm) thick, solidly fused plastic laminate with matte-finish melamine surfaces, colored face sheets, and black phenolic-resin core that are integrally bonded. Edges are black. Through-fixed extruded aluminum brackets allow the door to pivot between a structural aluminum headrail and floor fixed foot. Foot incorporates spring closing mechanism and includes height adjustment. Complete with anti-finger trap clearance on pivot side of door.

Outswinging doors come with a door stop bracket to keep them from swinging out past 90 degrees.

Divider— Class-A Fire-Rated Compact Grade Laminate (solid phenolic) 1/2" (12.7mm) thick, solidly fused plastic laminate with matte-finish melamine surfaces, colored face sheets, and black phenolic-resin core that are integrally bonded. Edges are black. Supported 9" (227mm) from the floor by anodized aluminum foot, with height adjustment.

Fascia— Where required, Class-A Fire-Rated Compact Grade Laminate (solid phenolic) 1/2" (12.7mm) thick, solidly fused plastic laminate with matte-finish melamine surfaces, colored face sheets, and black phenolic-resin core that are integrally bonded. Edges are black. If a fascia exceeds the width of 9", it will need to be supported by an aluminum foot.

Hardware— Anodized aluminum lock, able to be opened with a closed fist, is fixed through the door to the face plate for added strength. Sacrificial hard nylon shear tip to the lock finger, which locates directly into the vertical frame extrusion. Divider fixed to back wall using continuous brackets. Divider panels are secured using Pin-in-Head Torx Screw #12 X 7/16". Anodized aluminum coat hook supplied as standard. Latch allows door to be opened from the outside of the compartment with a standard Allen Wrench in the emergency release slot located in the indicator.

INSTALLATION:

Refer to Bobrick installation instructions packed with each shipment. Also available on bobrick.com. Form No. 2000000-69.

GUARANTEE:

Bobrick Evolve Cubicles including all hardware and mounting brackets are guaranteed to be free from defects in material and workmanship for a period of one year from date of purchase. Any products returned to Bobrick under this guarantee will be repaired or replaced at no charge.

10-Year Warranty— Bobrick extends a ten-year limited warranty from date of purchase for Compact Grade Laminate partition panels and doors against breakage, corrosion, delamination, and defects in factory workmanship when materials are properly installed, then used and serviced normally.

Evolve Cubicles of Bobrick Washroom Equipment, Inc., Clifton Park, New York; Jackson, Tennessee; Los Angeles, California; Bobrick Washroom Equipment Company, Scarborough, Ontario; Bobrick Washroom Equipment Pty. Ltd., Australia; and Bobrick Washroom Equipment Limited, United Kingdom.

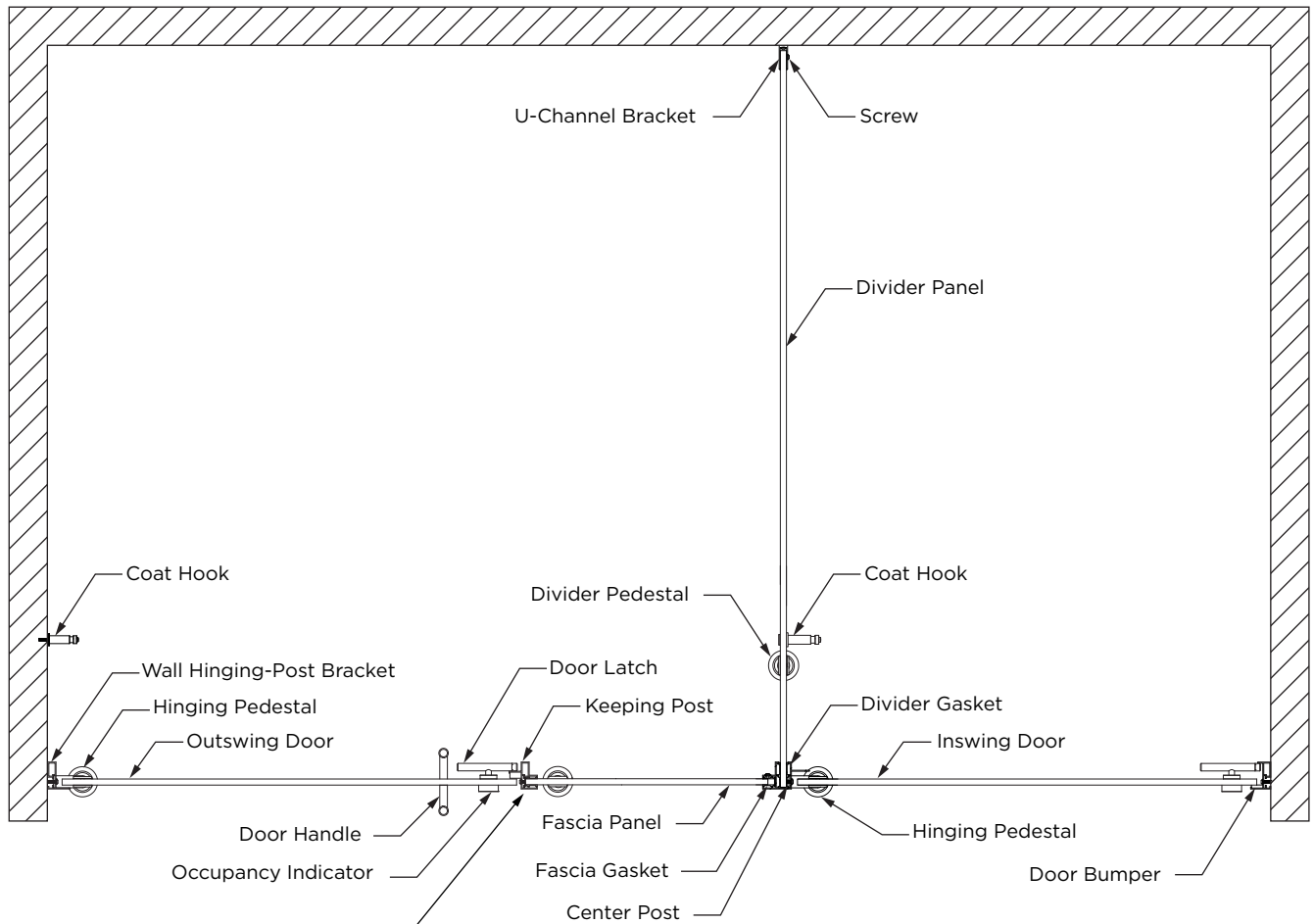

HARDWARE DETAILS

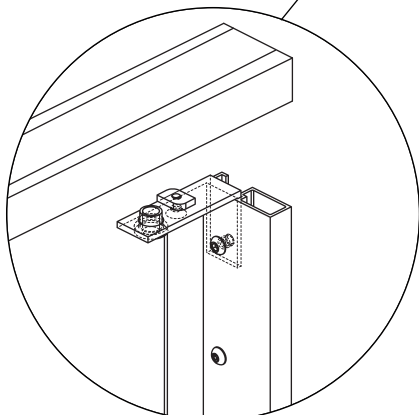

Overhead-Bracing Headrail

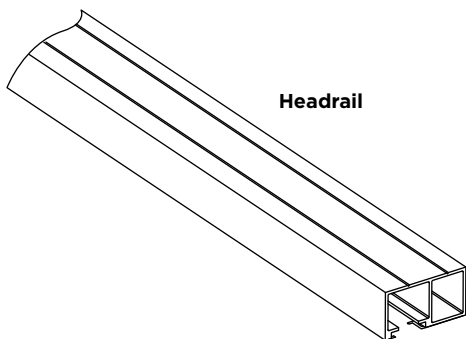

Headrail

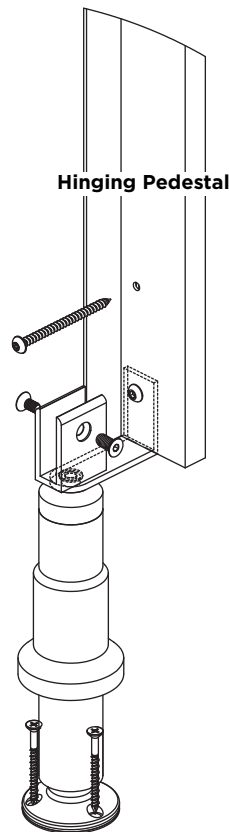

Hinging Pedestal

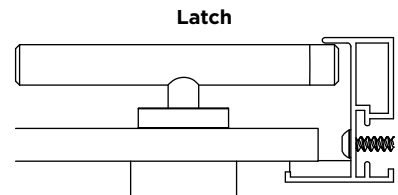

Latch

